

P950 TURBO

PROFESSIONAL AUTO-DARKENING WELDING HELMET

P950 TURBO is our “best seller” optoelectronic helmet, characterised by the use of 4 darkening sensors and external controls.

Provided with the True Color system, which ensures a clean and clear vision, it enables the operator to distinguish easily the objects in the work area with a lower eye strain.



CE EN 175
EN 379



APPLICATIONS



PLASMA

MIG (GMAW)

TIG (GTAW)
> 40A

SMAW

OXYGAS

GRINDING

OPTICAL CLASS	VIEWING AREA	FILTER DIMENSIONS	SENSORS	CONTROLS	LIGHT STATE	SHADE RANGE	UV/IR PROTECTION	SWITCHING TIME	DELAY
SENSITIVITY	POWER SUPPLY	REPLACEABLE BATTERIES	LOW BATTERY INDICATOR	NET WEIGHT					

P950 TURBO

Technical features and functions



- Optical class 1/1/1/2
- Viewing area dimensions: 100x60 mm
- Filter dimensions: 110x90x9 mm
- 4 arc sensors
- External shade control DIN 4 / 5-8 / 9-13
- Switching time < 0,3 ms
- External delay control: 0,1 - 1,0 s
- External sensitivity control
- Powered by battery + solar cells
- Weight: 500 g
- The external regulation allows to switch to the grinding modality without taking the helmet off.



PART NUMBERS AND SPARE PARTS

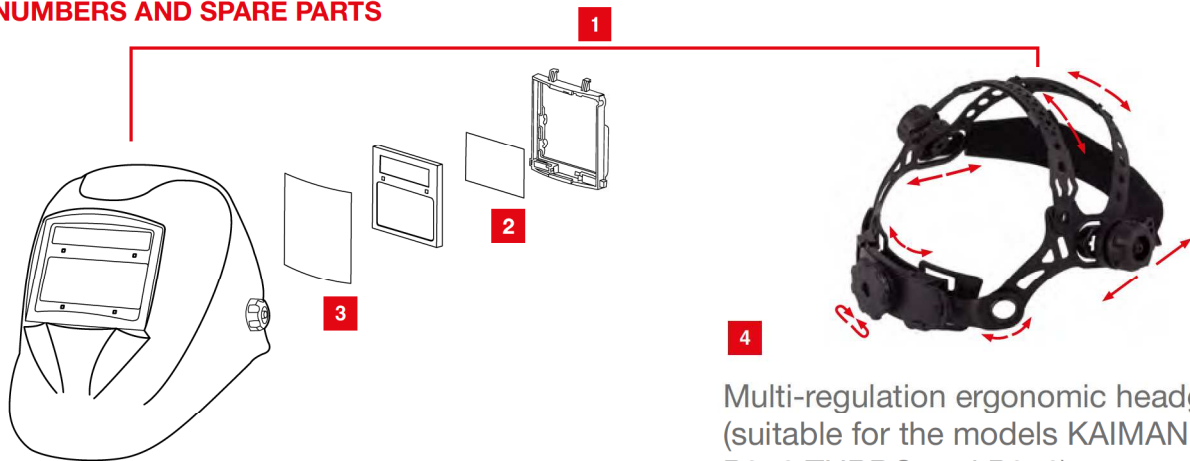

Multi-regulation ergonomic headgear (suitable for the models KAIMAN, P950 TURBO and P850).

	CODE	DESCRIPTION		
1	MSC000305	P950 TURBO auto-darkening welding helmet	110 x 90 mm	1
1	MSC000325	P950 TURBO auto-darkening welding helmet (BULK 25 PCS.)	110 x 90 mm	25
2	LVE000230	Internal protection plate (5 pcs)	100 x 63,5 x 1 mm	1
3	LVE000231	External protection plate (5 pcs)	115 x 104 x 1 mm	1
4	VCE000019	Headgear		1

TRUE COLOR SYSTEM

For a vision ever closer to reality

Better comfort and lower eye strain

The range of Sacit® helmets is provided with the TRUE COLOR system, a technology of the filter coating, that allows a realistic color perception and much more viewing clarity.



Thanks to the better contrast, the operator will be able to see the weld pool better, improving work accuracy.

The True Color system enables the operator to distinguish more easily the objects in the working area, with more comfort and less eye strain also during all the operating phases before and after welding.

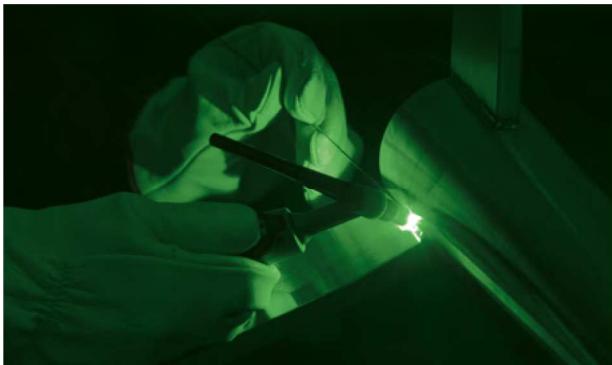

Standard Filter



True Colour filter



THE OPTICAL CLASS

The visual quality of the filter



The optical class is a system of evaluation and classification of the auto-darkening filters' performance in terms of viewing quality.

The ratings are incorporated in the European norm EN379.

This classification includes 4 parameters, which are scored on a scale of 1 to 3.

A score of 1 indicates the best performance, 2 intermediate, 3 is the worst rating.

Auto-darkening welding helmets rated with EN379 1/1/1/1 offer the best optical clarity.

The optical class is included in the filter marking.

FILTER MARKING

The filter is characterized by a degree of obscuration and an optical class.

The following is an example (EN379) :

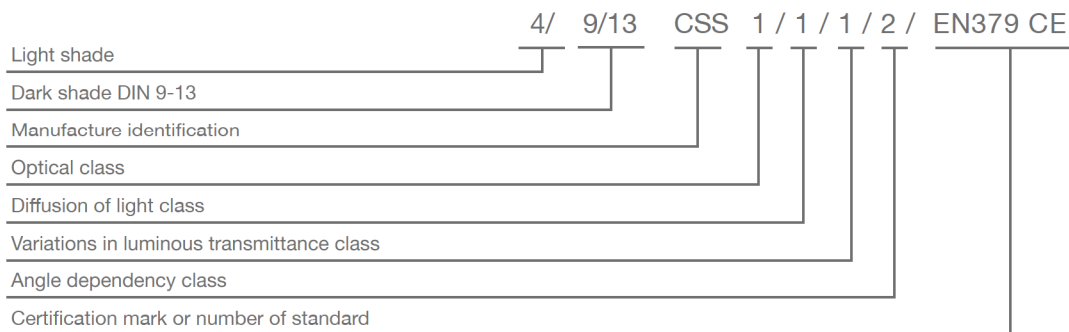

OPTICAL QUALITY

It indicates the level of definition of an image. The higher is the number, the bigger is the deformation/distorsion of the image through the lens.



LIGHT DIFFUSION

It indicates the visual clearness level. The higher is the number, the more the image will be out of focus.

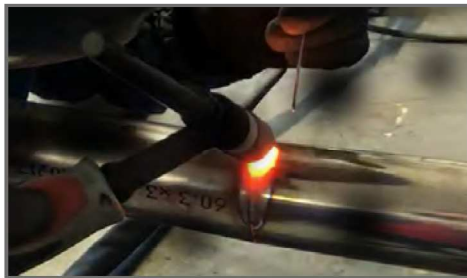

VARIATION OF THE LIGHT TRANSMITTANCE FACTOR

It indicates the degree of darkening homogeneity on the whole surface of the lens. The higher is the number, the bigger is the presence of areas darker or lighter than others.



ANGULAR VARIATION OF THE LIGHT TRANSMITTANCE FACTOR

It indicates the angular visual clearness degree. The higher is the number, the bigger is the elongation effect or the presence of other visual defects.

POWER SUPPLY SYSTEM

All the Sacit® auto-darkening helmets are powered by batteries + solar cells in support, and ensure a proper functioning also in not homogeneous or dark environments. Furthermore, the use of batteries ensures a higher darkening speed, compared to that of helmets powered only by solar cells.

STANDBY AND SLEEP-MODE AUTOMATIC ACTIVATION

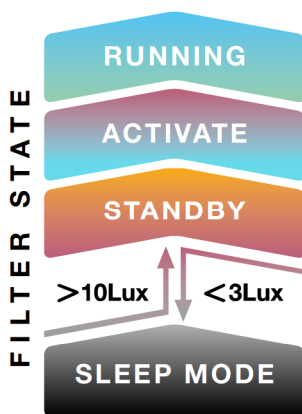

PANTERA and TIGER TOP filters feature the STANDBY mode automatic activation system.

When the ambient light intensity is less than 3Lux, the filter switches off automatically and the consumed current is less than 1uA afterwards (SLEEP MODE).

When the ambient light exceeds 10 Lux, the filter switches on automatically entering the STANDBY mode.

The STANDBY system is automatic and helps saving power consumption and environmental protection.

Delay setting

The function “Delay” permits to set the intermediate time between dark and light to protect the welder’s eyes from the flashes after welding.

The setting MAX (1 sec) is particularly suggested for applications with high currents and for TIG (GTAW) welding in order to prevent the filter opening in case the light beam is temporarily obstructed by the hand, by the torch, etc.

The setting MIN (0,1 sec) is suggested for tack-welding applications.

Sensitivity setting

The function “Sensitivity” permits to regulate the filter sensitivity to the welding process and to the ambient light.

The setting “HI” (High) is suggested in all welding operations and in particular in those with low amperage or in environments in which light is not sufficient for welding.

The setting “LO” (Low) is suggested only in the presence of specific surrounding light conditions, in order to avoid an unwanted start up (for example caused by direct sunlight, by intense artificial light or by a welding torch nearby).